

**Appendix A to Subpart C of Part 178—Illustrations: Cylinder Tensile Sample**

The following figures illustrate the recommended locations for test specimens taken from welded cylinders:

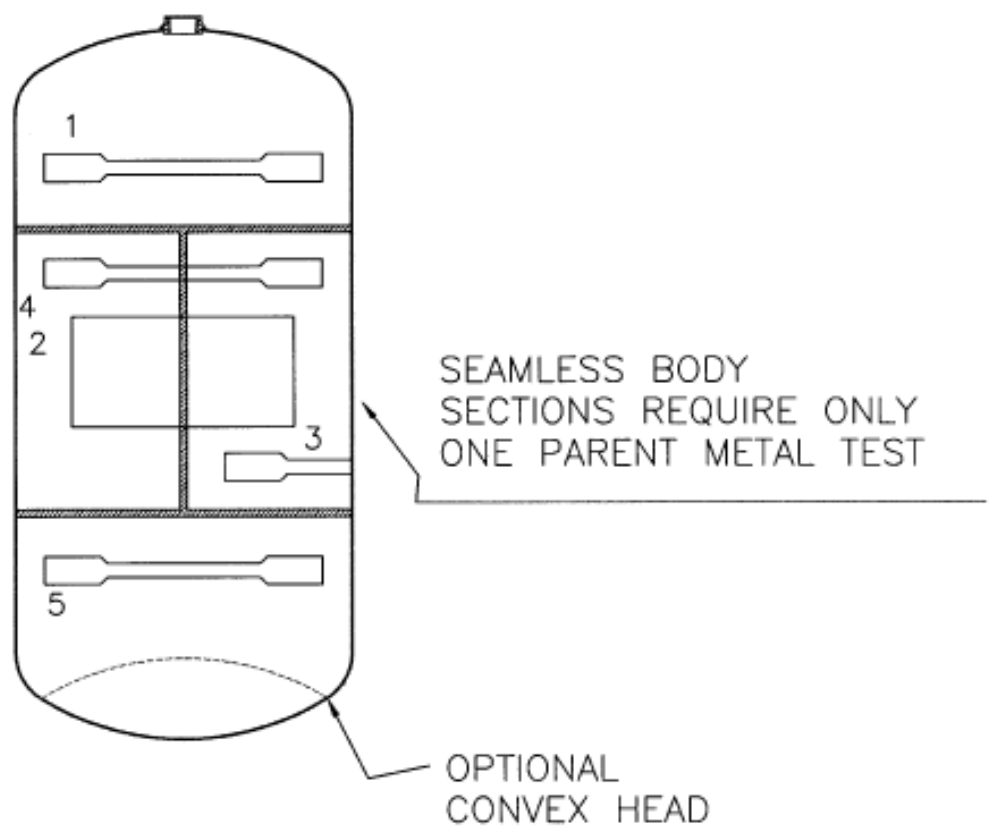

PARENT MATERIAL TEST  
SAMPLE 1 & 3 & 5



WELD TENSILE TEST  
SAMPLE 4



WELD BEND TEST  
SAMPLE 2

THIS FIGURE ILLUSTRATES THE PROPER TENSILE LOCATION FOR A 3 PIECE CYLINDER WITH THE HEADS

THIS FIGURE ILLUSTRATES THE PROPER TENSILE LOCATION FOR A 3 PIECE CYLINDER WITH THE HEADS HAVING STRAIGHT SIDEWALL.

FIGURE #1

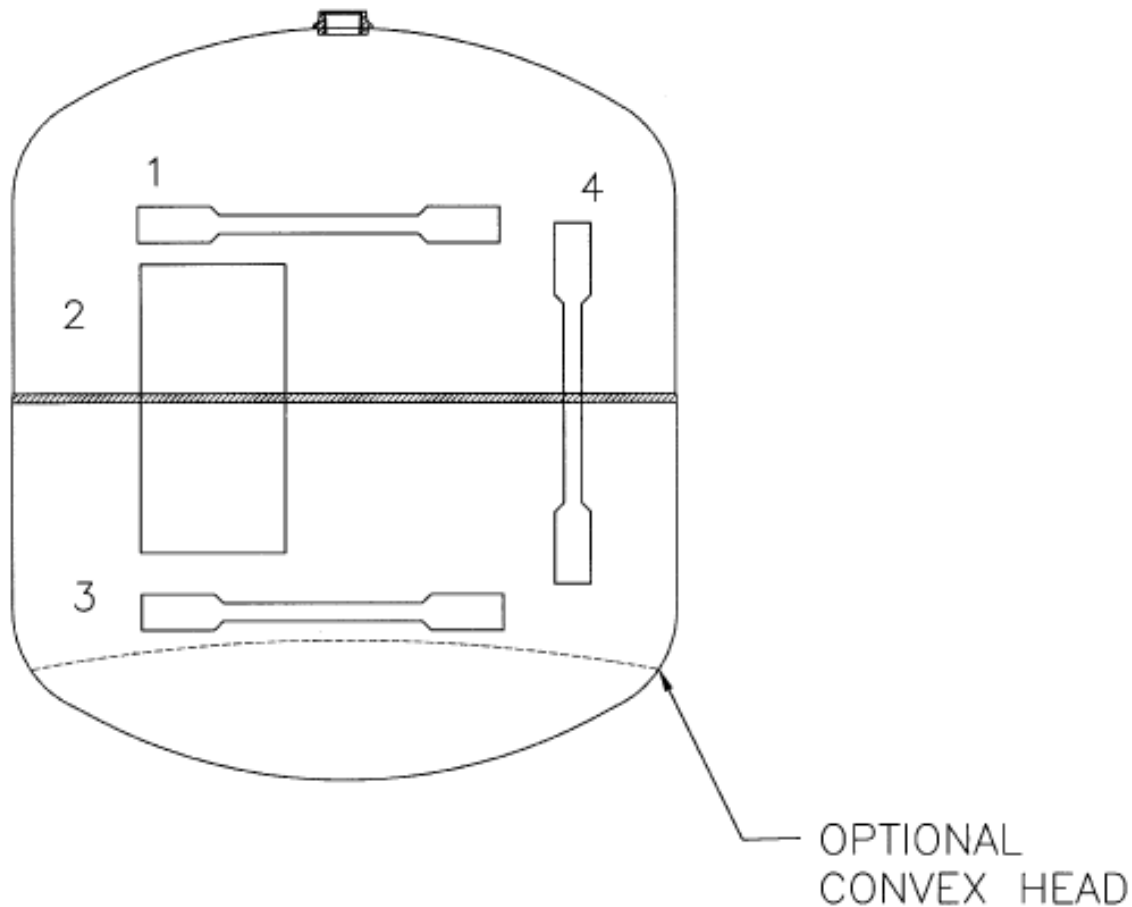

 PARENT MATERIAL TEST SAMPLE 1 & 3

 WELD TENSILE TEST SAMPLE 4

 WELD BEND TEST SAMPLE 2

THIS FIGURE ILLUSTRATES THE PROPER TENSILE LOCATION FOR A 2 PIECE CYLINDER WITH THE HEADS HAVING STRAIGHT SIDEWALLS.

LOCATION FOR A 2 PIECE CYLINDER WITH THE HEADS HAVING STRAIGHT SIDEWALLS.

FIGURE #2

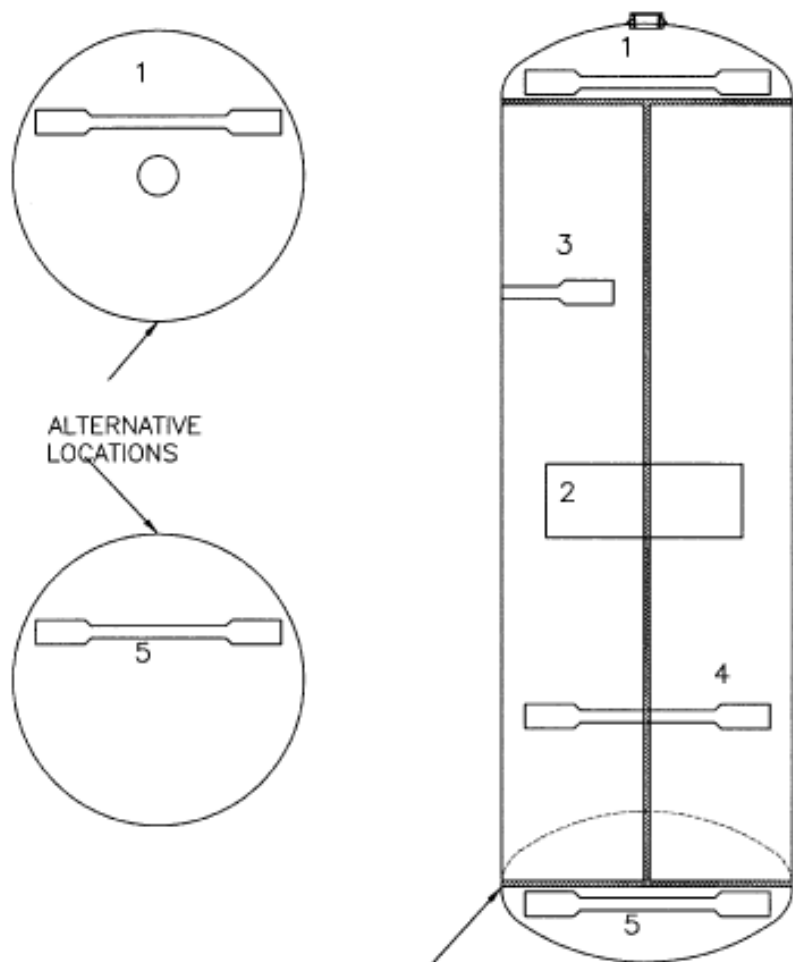

ALTERNATIVE LOCATIONS

OPTIONAL, CONVEX HEAD SAMPLE TO BE TAKEN FROM HEAD

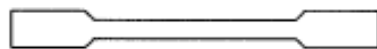

PARENT MATERIAL TEST SAMPLE 1 & 3 & 5

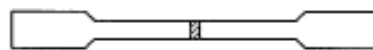

WELD TENSILE TEST SAMPLE 4

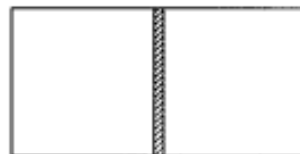

WELD BEND TEST SAMPLE 2

THIS FIGURE ILLUSTRATES THE PROPER TENSILE LOCATION FOR A 2 PIECE CYLINDER THAT HAVE DEEP DRAWN HEADS.

FIGURE #3

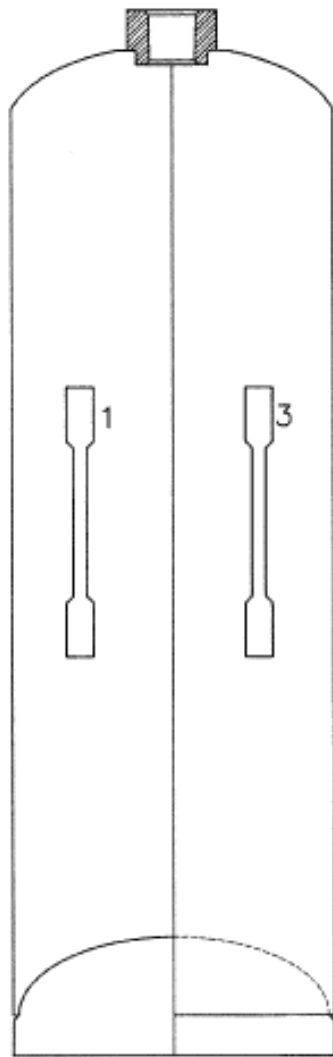

SEAMLESS SIDEWALL  
CONSTRUCTION

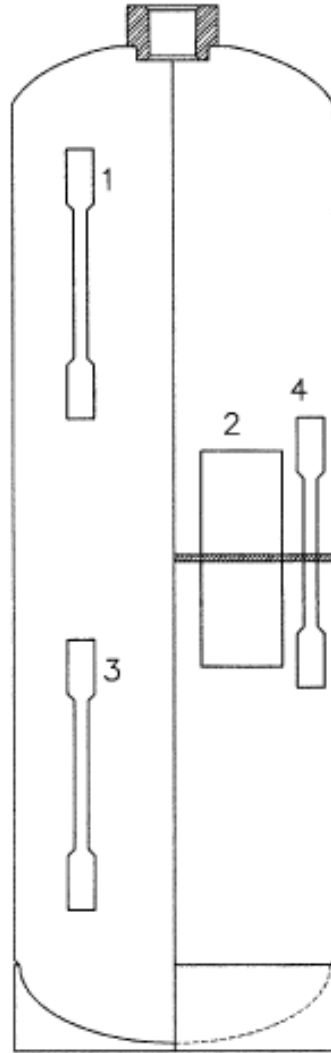

TWO PIECE  
CONSTRUCTION



PARENT MATERIAL TEST  
SAMPLE 1 & 3

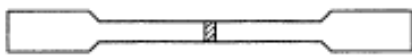

WELD TENSILE TEST  
SAMPLE 4



WELD BEND TEST  
SAMPLE 2

THIS FIGURE ILLUSTRATES THE PROPER TENSILE  
LOCATION FOR A 2 PIECE CYLINDER THAT HAVE DEEP  
DRAWN HEADS.

FIGURE #4

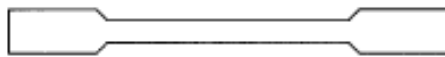
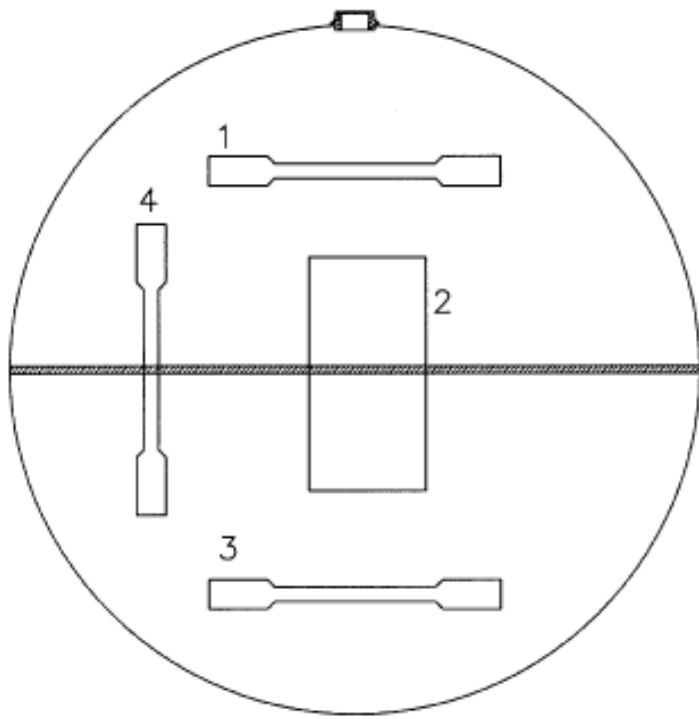

PARENT MATERIAL TEST  
SAMPLE 1 & 3

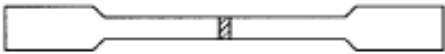

WELD TENSILE TEST  
SAMPLE 4



WELD BEND TEST  
SAMPLE 2

THIS FIGURE ILLUSTRATES THE PROPER TENSILE  
LOCATION FOR A 2 PIECE CYLINDER.

FIGURE #5